

# FM400 Centrifuge

## Technical Data



en 0817 © MANN+HUMMEL

### BENEFITS

- Cleaner oil and extended oil life
- Lengthens service intervals
- Reduces engine wear
- Enhances long-term preventative maintenance
- Reduces maintenance costs
- Cuts waste disposal costs
- Reduces application down time
- Maximises in-service time for vehicle/engine/machine
- Reduces total cost of ownership
- Helps ensure clean combustion and fuel efficiency
- Supports engine technology for the reduction of exhaust emissions (e.g. exhaust gas recirculation)

### DIMENSIONS (mm)

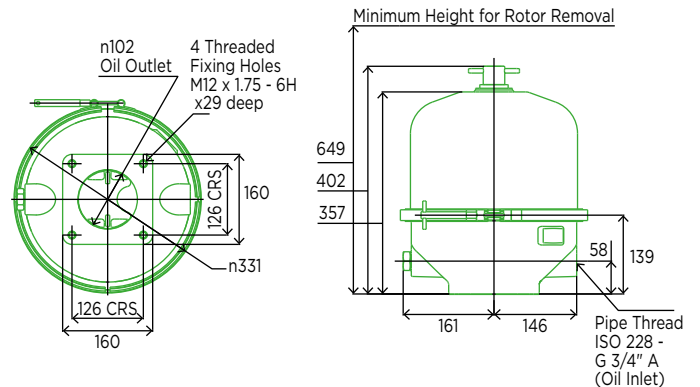

<b>Model</b>	<b>FM400-23</b>
<b>Part number</b>	68 991 38 801
<b>Oil inlet thread</b>	3/4" B.S.P.*
<b>Cut Off Valve (C.O.V.) ratings</b>	2.5 bar*
<b>Threaded fixing holes</b>	M12
<b>Net weight</b>	22 kg
<b>System capacity</b>	200 - 1,500 litres
<b>Rotor dirt capacity</b>	4 litres
<b>Rotor oil capacity</b>	4.5 litres
<b>Minimum oil feed pipe size</b>	Ø 19 mm internal
<b>Minimum oil drain pipe size</b>	Ø 76 mm internal

### PERFORMANCE CURVES

Typical Rotor Performance for SAE 30 Oil @ 100°C

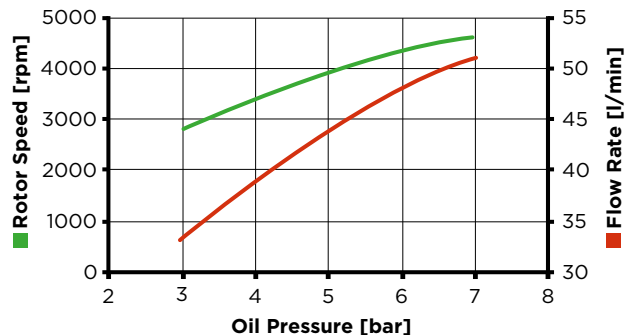

\*Can be tailored to suit customer requirements

Authorised Distributor



t: +44 1264 860186  
e: spares@simplexturbulo.com

STC is a member of SIMPLEX ENGINEERING GROUP

Leadership in Filtration

**MANN+HUMMEL**